

INDUSTRIAL VERTICAL AXIS CENTRIFUGES WITH AUTOMATIC BOTTOM DISCHARGE TYPE DEC



RC 85 Vx DECR

KEY FEATURES OF DEC TYPE CENTRIFUGES



PERFORMANCE

- Suitable for large quantities of material.
- Possibility of running as a closed system under a controlled atmosphere to prevent operator exposure and product or environmental contamination.



FLEXIBILITY

- Wide range of automatic discharge vertical axis basket centrifuges.
- 7 basket diameters / 8 (and more) basket capacities.
- Centrifuge design suitable for all types of feeding solutions and any cake consistency.



TAILOR MADE EQUIPMENT

- Tailor made technical design and features.
- Very large choice of optional equipment and ancillaries .

GENERAL DESIGN OF DEC TYPE CENTRIFUGES

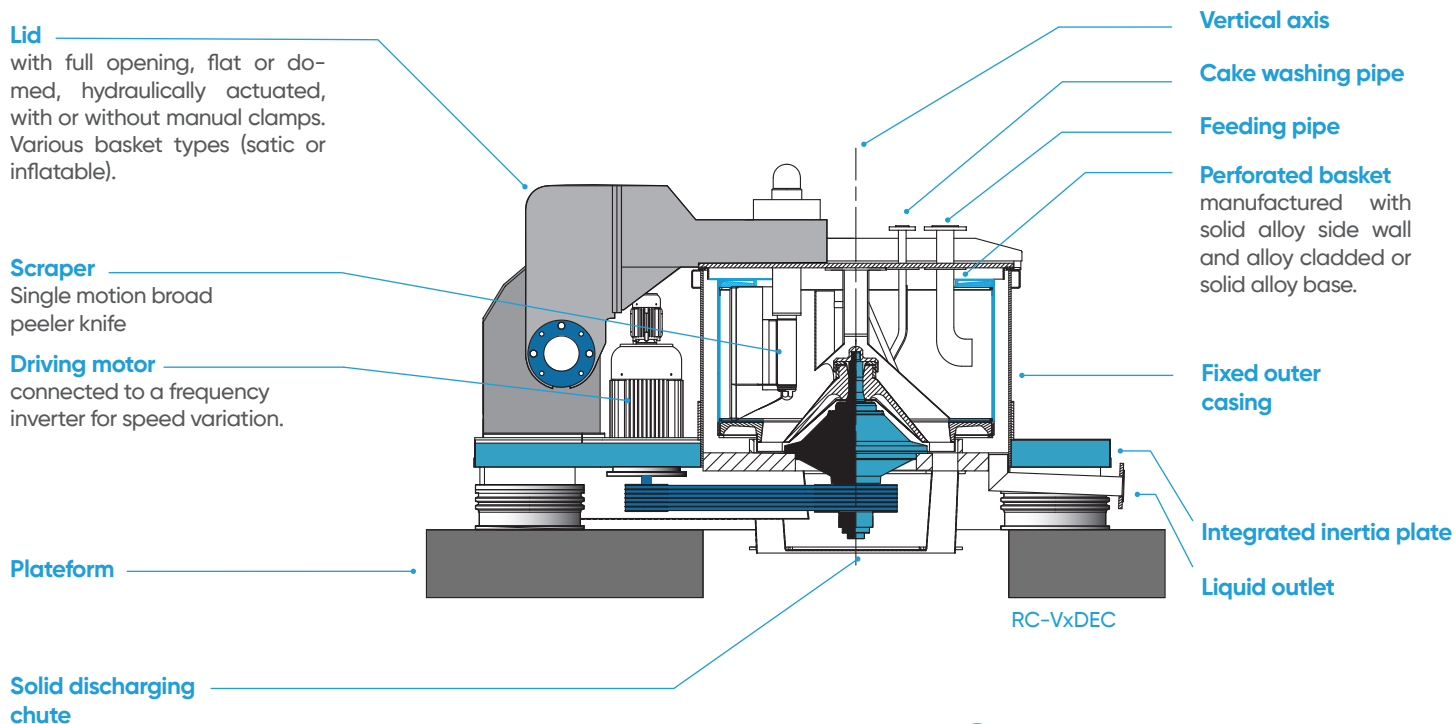

FOCUS ON THE VARIOUS VERSIONS

«HI-TECH» VERSIONS

- **Fully-opening outer casing:**
When combined with a flat bottom basket, it allows immediate visual inspection and integral cleaning of all process contact surfaces.
- **Quick release basket** for periodic inspection and cleaning, used in conjunction with a fixed casing design.



SIMPLIFIED VERSIONS

- **Materials of construction:** cast iron and stainless mild steels. Outer casing with **partial opening cover** or half lid opening (manually or hydraulically activated). In this version, all internal equipment is fixed on the upper casing.
- **Cycle:** manually controlled cycle.



CYCLE STEPS & ADDITIONAL FUNCTIONS

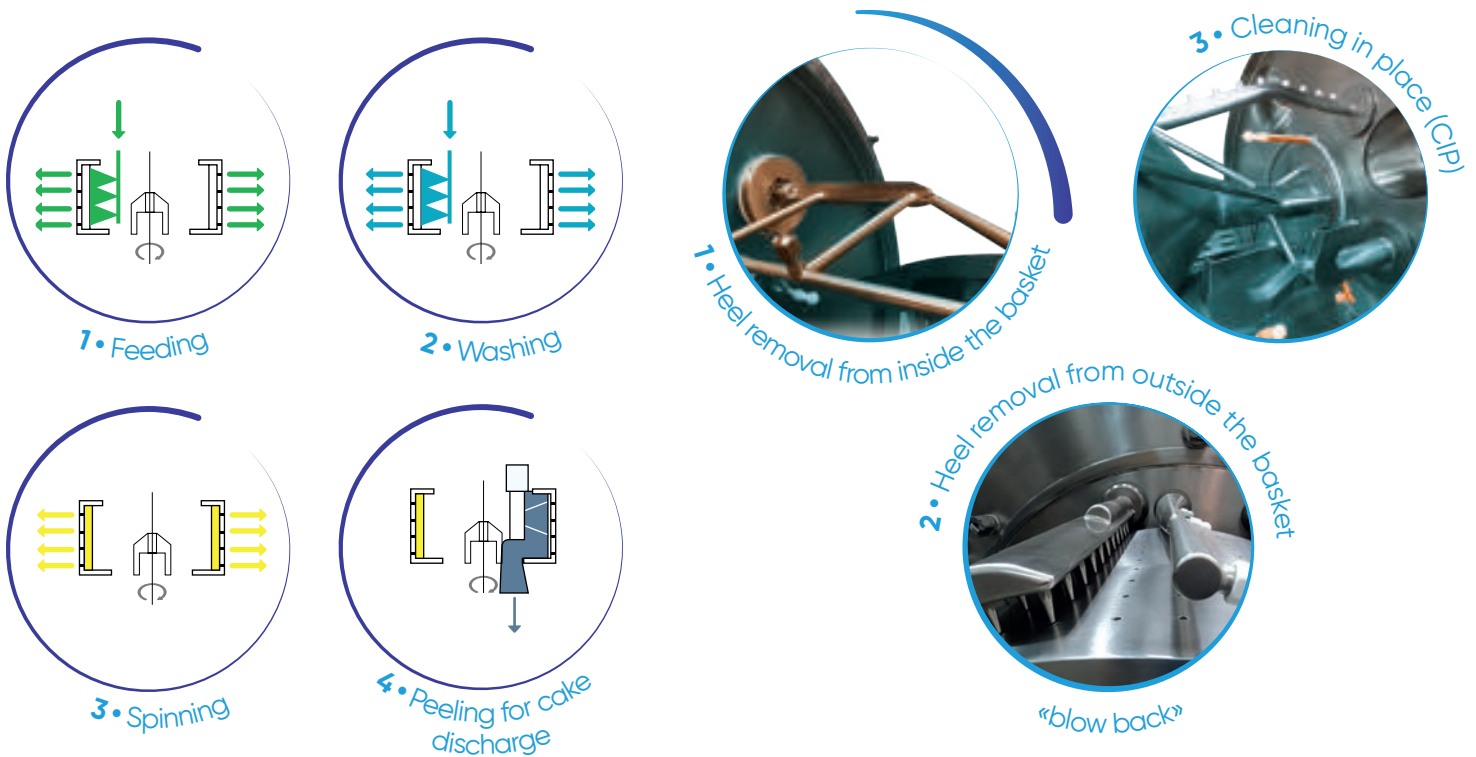

1 • FEEDING

- **With single or double mouth fixed pipe** (adjustable in height and orientation when machine is stopped) or with “up and down” motion adjustment in frequency and movement during centrifuge operation optimizing product distribution over the entire height of the basket.
- **Feed control:** Detector, with nor without contact, to optimize filling and prevent any risk of overflowing during feeding and washing.

2 • WASHING

With **fixed pipe**, adjustable when machine is stopped, with interchangeable in orientation spray nozzles.

3 • SPINNING

Possibilité d'effectuer plusieurs lavages, à des vitesses et des temps différents dans un même cycle.

4 • PEELING AND CAKE DISCHARGE

- **Scraping** by single motion peeler knife extending over the entire height or double motion with axial and radial movement. Interlocked for safety, adjustable advance speed, quick release and replaceable blade.
- **Discharge** through openings in the basket and the housing base which diverts the solids into a simple chute or vapour-tight chute with associated valve for connection to downstream equipment.

• RESIDUAL HEEL REMOVAL two optional devices available:

- **Removal from inside the basket:** Gas lance installed on peeler blade or independent mechanism with double motion (axial and radial movement)¹ using network pressure or high pressure which is generated using a compressor.
- **Removal from outside the basket (blow-back)²:** battery of spray nozzles installed on the inside of the centrifuge casing allowing (neutral) gas blowing back to dislodge the heel from the filter cloth by generated vibration.

• CLEANING IN PLACE (CIP)³ :

With strategically located rotating heads and spray nozzles for cleaning of basket and process contact areas.

MAIN DESIGN FEATURES

- **Main Drive:** side-mounted one speed electric motor with speed control by variable frequency drive and transmission via antistatic belts..
- **Centrifuge mounted electrical equipment:** water-tight or explosion-proof according to European norms EN 60079...(ATEX compliance for the EU) or to North American ones.
- **Local control panel:** independent,

installed near the centrifuge with necessary instrumentation and safeties.

- **Main control panel:** independent, installed outside the processing area, in technical one, with separate drive and control panels.

- **Hydraulic unit:** for controlling peeler motion, lid motion, and optional “up and down” feeding pipe and outer casing motion, installed near the centrifuge.

- **Cycle control:** fully automatic or cycle-by-cycle, with manual intervention and possible DCS communication.

- **Safety:** fully equipped with safety features and ancillary systems. Vibration detector or unbalance switch, speed sensor, pressure switch,...

TECHNICAL CHARACTERISTICS OF DEC RANGE

TYPE	Basket						
	∅ mm	Height mm	Useful volume l	Load kg	Filtration area m ²	Speed rpm	Centrifugal force "G"
RC 63 Vx DEC	630	370	50	62	0,73	1500	792
RC 85 Vx DEC	850	425	130	162	1,13	1300	803
RC ou SC 100 Vx DEC	1000	500	170	215	1,57	1000	559
RC ou SC 120 Vx DEC	1200	600	310	390	2,26	1050	543
RC ou SC 125 Vx DEC	1250	630	395	495	2,47	1200	1006
		800	500	625	3,14		
RC ou SC 150 Vx DEC	1500	750	580	725	3,53	900	679
RC 160 Vx DEC	1600	1000	1000	1250	5,03	900	724

Optional equipment and auxiliaries

- **Installation:** 3 column suspension (SC) or rigid type, with integrated inertia plate and vibration isolators (RC).
- Various **construction materials** (stainless steels, Alloys...), **coatings** (rubber, HALAR...) and **gasket materials**.
- **Vapor tightness** for operation under inert gas blanketing.
 - **ATEX compliance** (for the EU), **cGMP** construction.
- **Inerting Control Systems** (various principles : Pressure control, Oxygen content analysis, Neutral gas inlet flow control).
- **Hydraulic siphon** or liquid receiver for liquid outlet tightness.
- **Several possibilities for control systems** from completely manual to fully automatic with local HMI and possibility of plant networking.
- **Surface finish:** various polishing grades to meet application and customer requirements (electro polishing available).
 - Different **cake detector types**.
- **Single or two-piece splash deflector** (depending on models).
- **Liquid skimmer pipe / double shell casing / solid bowl decanter version.**



HEADQUARTERS

ROUSSELET ROBATEL
45 Avenue Rhin et Danube
Parc d'activité économique de Marenton
07104 ANNONAY - FRANCE
Tel. : +33 (0)4 75 69 22 11
E-mail : info@rousselet-robotel.com

UK

Rousselet UK Ltd
Parkside House, 17 East Parade
HARROGATE
NORTH YORKSHIRE HG1 5LF
Tel. : + 44 (0)1 423 530 093
E-mail : info@rousselet-robotel.com

DEUTSCHLAND

ARRGOS GmbH
Max-Eyth-Str. 1
D-71691 Freiberg a.N.
Tel : +49(0)7 7229 20
Fax : +0)173 757 6226
Email : nicolas.kiehl@arrgos.de

USA

Robatel Inc.
703 West Housatonic Street
PITTSFIELD
MA 01201
Tel: + 1 413 499 4818
E-mail : sales@rr-centrifuge.com